

Versatile Servo Drive VSD-E & VSD-XE

Evolution

Table of Contents

1.Introduction.....	2
2.Important notices.....	3
3.Electrical specifications.....	4
4.Features.....	5
5.Terms and definitions.....	7
6.Physical overview.....	8
7.Connectors.....	9
7.1 Power connector.....	9
7.2 Motor connector.....	10
7.3 Encoder connector.....	11
7.4 CMD connector.....	13
7.5 EXT connector.....	15
8.Installation notes.....	16
8.1 Wiring.....	16
8.2 Grounding.....	16
8.3 Shielding.....	17
8.4 Protection.....	17
8.5 Cooling.....	17
8.6 Regenerative resistor.....	18
8.7 Connection to motor & controller.....	19
9.Power supply.....	20
9.1 Basic guide for sizing linear PSU components.....	20
9.2 Example circuits.....	21
9.3 Power-up sequence.....	22
10.Drive logic.....	23
10.1 Main operation modes.....	23
10.2 Input command processing.....	24
10.3 Motor control algorithms.....	24
10.4 Limits & fault monitoring.....	26
10.5 Configurable I/O functions.....	27
11.LED status indicators.....	28
12.Physical command inputs.....	29
12.1 SPI input.....	29
12.2 Step & Dir inputs.....	29
12.3 Quadrature inputs.....	29
12.4 PWM & Analog inputs.....	30
12.5 Indexer inputs.....	30
13.Motor compatibility.....	31
13.1 Motor configurations & output currents.....	32
14.Troubleshooting.....	33
15.Mechanical dimensions.....	34

Note: this manual mostly discusses about VSD-E, but same specifications apply also for **VSD-XE**. The differences of drive models are listed in chapter 13.1 *Motor configurations & output currents* (p. 32).

Specifications are subject to change without notice.

1. Introduction

Thank you for choosing Granite Devices VSD drive!

This manual will give an detailed view of drive electrical & mechanical specifications and will guide for proper installation.

Chapter **2 Important notices** will notify about important safety concerns and status of current firmware.

Chapter **3 Electrical specifications** contains tabular data of drive electrical properties.

Chapter **4 Features** lists the most important features of VSD-E.

Chapter **5 Terms and definitions** describes the most important terms used in this manual.

Chapter **6 Physical overview** gives overview of electromechanical aspects & connector locations.

Chapter **7 Connectors** describes connector pin-outs and circuitry behind these connectors.

Chapter **8 Installation notes** describes how to properly install drive in a enclosure.

Chapter **9 Power supply** describes how to choose or build suitable power supplies.

Chapter **10 Drive logic** describes the internal logic & algorithms of drive.

Chapter **11 LED status indicators** lists the LED indicator meanings.

Chapter **12 Physical command inputs** describes the control interfaces of drive.

Chapter **13 Motor compatibility** helps to determine if motor is compatible to VSD-E.

Chapter **14 Troubleshooting** contains answers for the most common troubles.

Chapter **15 Mechanical dimensions** contains mechanical dimension of the drive.

For practical approach to drive installation, please also read **Getting Started with VSD-E & VSD-XE** manual (downloadable from product site).

2. Important notices

Be sure to read through this VSD-E documentation and understand it completely before operating the device. If case of questions, please contact us for support.

Warnings and hazards

This drive has been designed to be operated on **isolated DC power supply** only. Optoisolator isolation distance (creepage) on circuit board is less than 2 millimeters.

A recommended way for **emergency stopping** is to cut HV bus voltage and activating motor brake if possible. Using optoisolated *disable* input may not be enough for emergency stopping.

Drive should be installed in **ventilated** enclosure. Dust filters are recommended when fans are used. The worst case operating temperature should not exceed 70 Celsius degrees (measured from aluminum plate).

Drive **should not be used** in applications where failure or malfunction could lead to danger, large financial loss, health hazard, injury, death, or other unbearable loss. Granite Devices can't be held responsible if such risks are taken.

This document may contain human **errors**. When operating with drive, take every precaution you can. Granite Devices do not take any responsibility of damages that may be caused by following or not following this document.

Failure to follow given guidelines or operating outside given specifications may damage the device and will **void warranty**. In uncertain cases always contact us for clarification.

Granite Devices reserves rights to make changes to this document and specifications without notice.



Status of stepping motor support

The stepping motor support in VSD-E firmware version 1.20 is **preliminary** and intended for development use only. Customers are recommended to wait for final stepper motor support before using VSD-E for steppers. When ready, the upgrade will be freely downloadable from Granite Devices web site.

However, the firmware V1.20 is **already able to control stepper as high pole count sinusoidal AC servo motor** (with encoder). This can be achieved by entering following configuration parameters in GDtool

- Motor type: AC
- Pole count: 100 (1.8 deg/step motors)
- Motor phase count: 2

As back EMF voltage constant of stepping motors is relatively high, this mode provides only limited speed operation. Typical characteristics of this mode are:

- Typical top speed 500-1500 rpm
- Uninstallable
- Precise torque control available
- No mid-band resonance problem

The upcoming firmware upgrade will provide following additional properties:

- Operation to high speeds (up to 7000 rpm)
- Operation also without encoder
- Digital mid-band resonance damping

3. Electrical specifications

	<i>Description</i>	<i>Min.</i>	<i>Typ.</i>	<i>Max.</i>	<i>Units</i>	<i>Notes</i>
--	--------------------	-------------	-------------	-------------	--------------	--------------

Device operating conditions	Logic supply voltage	8	12	13.5	Vdc	
	HV supply voltage	12		84	Vdc	Max surge 90 Vdc
	Logic supply current consumption	200		700	mA	200 mA + user +5V_OUT load
	+5V_OUT load (combined ENC, CMD, EXT)	0		400	mA	Total load
	HV supply current consumption	0.05		38	A	Depends on motor load
	Operating temperature (heatsink & PCB)	10		70	°C	
	Humidity	0		95	%	Non-condensing
	Power dissipation	2		TBD	W	

Encoder	Encoder count rate	0		4	MHz	After 4X decoding, digitally filtered
	Encoder supply voltage	4.8	5.0	5.2	V	
	A, B, Z inputs impedance	2000			Ohm	See figure 5 (p. 11)

I/O (CMD) characteristics	SPI bus baud rate	0		80	kbit/s	
	Output optoisolator drive capability	0.5			mA	See figure 9 (p.14)
	Output optoisolator supply voltage	3		6	Vdc	Voltage diff. from pin IO_VCC to IO_COM
	Optoisolator input threshold current (logic 1)			6.3	mA	All inputs
	Optoisolated digital logic input voltage compatibility	3.0 to 5.5V CMOS or TTL logic. Greater voltage range by external resistor.				All inputs
	Optoisolator minimum logic 1 hold time	125			ns	HSI1 & HSI2 inputs
	Optoisolator minimum logic 0 hold time	125			ns	HSI1 & HSI2 inputs
	PWM mode input frequency	3	5..30	100	kHz	
	Analog input voltage range	-11		+11	V	AIN1 & AIN2

Motor control characteristics	Motor continuous output current	See chapter 13.1 on page 32			A	
	Motor peak output current	See chapter 13.1 on page 32			A	
	Peak current duration			2	sec	
	Motor output switching frequency		20		kHz	
	Effective motor output voltage swing			88	%	Percentage of HV voltage
	Torque control bandwidth		1-3.3		kHz	Motor dependent
	Feedback (PID) loop sampling frequency		2.5		kHz	
	Efficiency		95		%	At full power
		Motor inductance (per HV supply voltage)	0.005			mH/V

4. Features

Motor support

- Supports AC, BLDC, brushed DC servomotors and 2 & 3 phase stepping motors
- Unstoppable stepper control (with encoder feedback), operates like a servomotor
- AC/BLDC motor support with and without Hall sensors

Position control

- Relative and absolute position commands
- Infinite motion range
- Configurable 32 bit absolute position limits after homing
- Configurable velocity and acceleration limits
- Soft recovery from error, configurable recovery speed
- Drive tracks position during fault and restores to correct position after clearing the fault

Velocity control

- Configurable velocity and acceleration limits
- Soft recovery from error
- Configurable input command sensitivity

Command inputs

- Optoisolated step/direction input (step on rising edge)
- Optoisolated quadrature input
- Optoisolated PWM input
- Optoisolated SPI (Serial Peripheral Interface) bus
- +/- 10V analog input
- Input smoothing filter
- Configurable fractional scaling or gearing ratio
 - Input multiplier from 1 to 32767
 - Input divider from 1 to 32767

PID & PIV controller

- Anti-windup design
- User selectable 32 bit PID or PIV filter
- Acceleration and velocity feed-forwards
- Adjustable anti-dither region with separate PID/PIV gains
- 2.5 kHz update rate

Torque controller

- Field oriented sinusoidal flux vector control

- Tunable anti-windup PI torque controller
- Full PWM frequency update rate (50 μ s)
- High dynamic range torque control (HDRT), 1.8 mA current sensing resolution
- HV bus voltage variation compensation, voltage doesn't affect tuning
- Adjustable torque command low pass filter (100 - 3300 Hz)

Homing controller

- Fully configurable homing sequence can be combined from
 - Home switch or hard stop search, settable direction
 - Encoder index pulse search, settable direction
 - Adjustable 32 bit position offset move after homing
- Automatic homing after power-up or manual homing by a command
- Configurable torque, acceleration and velocity limits for homing sequence

Fault detection & protections

- Configurable following error limits from 1 to 16383 units (position encoder counts or velocity error)
- Configurable motion fault detection with 0.2 second response time
 - Sensing of DC motor runaway
 - Sensing of stepping motor stall when encoder feedback is present
 - Sensing of blocked motion
- Overvoltage detection and power stage shutdown to prevent failures caused by regenerative braking current
- Undervoltage detection
- Configurable overcurrent detection and shutdown
- Short circuit protection
- On-board HV power fuse
- Overtemperature protection
- Motor heat temperature modeling (I^2t protection)
- Internal program & data memory error detection
- Input command range error detection
- SPI communication error detection

Other features

- User configurable general purpose inputs/outputs on unused pins
- Field upgradeable firmware
- Eased panel installation
- Mounting for optical fibers for bringing LED signals to front panel
- Regenerative brake resistor output (limitations apply, see chapter 13.1 on page 32)
- Connector with pass-through encoder signals for external controller

It should be noted that some of these features are new and current release of GDtool configuration software may not support them until the next release.

5. Terms and definitions

Term	Definition
Controller	<p>External motion controller or command source that controls VSD drive. Typically a PC, SPI adapter, PLC, step pulse source, PWM source, +/-10V source, mechanical switches, master encoder or potentiometer.</p> <p>There are two main types of controllers:</p> <ul style="list-style-type: none"> ● Devices which produce only <i>target</i> signal to drive and drive does all motor controlling internally. In this type. controller does not need to get any feedback from motor (i.e. encoder signals). ● Devices which close control loop in them. In these devices, the controller requires feedback from motor (i.e. encoder signal) and uses it to produce velocity or torque command to drive.
Drive	VSD-E drive
RMS	Root Mean Square.
FG	Frame Ground. A ground potential of enclosure and D-Sub connector metal shells of drive. FG is internally connected to drive GND through a bypass capacitor.
GND	GND is drive ground potential which is present in following connectors: POWER, ENC, CMD and EXT. All "GND" pins in all connectors are internally connected together to same potential.
+5V_OUT	5V output (against GND) from several connectors. All +5V_OUT:s are in same potential and share a common current loading limit (see Electrical specifications).
HV+	A high voltage & high current supply for drive. Motor power is drawn from HV+.
Logic supply	A logic circuitry voltage supply for drive
Cable shield	A metallic EMI shield (foil or braid) inside cable surrounding all wires.
Regenerative resistor	An optional external resistor that can be used to dissipate returned energy from motor when motion is braking or decelerating. Can prevent supply voltage pumping and overvoltage.

6. Physical overview

All the listed features are documented in more detail in the following chapters.

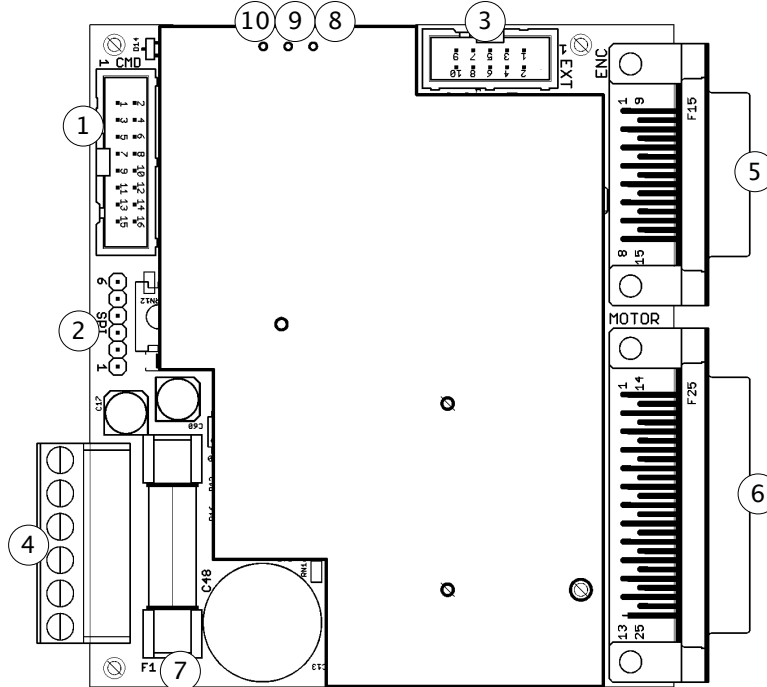

Figure 1: VSD-E physical layout

# in Figure 1	Name	Description	Type	Mating part
1	CMD	User command I/O port	8x2 pin header (0.1" centers)	16 pin IDC connector (kit)
2	SPI	SPI port	6x1 pin header (0.1" centers)	GD USB adapter (ordered separately)
3	EXT	Encoder pass-thru & led output signals	5x2 pin header (0.1" centers)	10 pin IDC connector (kit)
4	POWER	Power supply & brake resistor connector	Removable terminal block	(included)
5	ENC	Encoder, Hall sensors and home switch input	15 pin female D-Sub connector	15 pin male D-Sub connector (kit)
6	MOTOR	Motor output connector	25 pin female D-Sub connector	25 pin male D-Sub connector (kit)
7	F1	HV power fuse	0.25x1.25" (6.35x32 mm)	3AG or 3AB fuse (included)
8	LED1	Green indicator led	Green led	Plastic core optical fiber (kit)
9	LED2	Blue indicator led	Blue led	Plastic core optical fiber (kit)
10	LED3	Red indicator led	Red led	Plastic core optical fiber (kit)

Notes

- All mating connectors are included in optional VSD-E installation kit (ordered separately)
- Optional optical fiber can be used to bring led signals to enclosure front panel

7. Connectors

7.1 Power connector

This is a modular (removable) high current connector for **logic supply**, **high voltage supply** and **regenerative resistor**. For high current (>10 A) applications dual wiring for GND and HV+ should be used to minimize resistance.

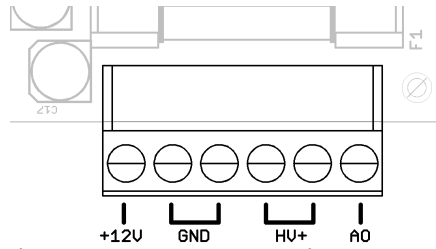

Figure 2: Power connector pin out

Signal name	Function
+12V	Positive logic supply voltage
GND	Ground (2x), connected parallel internally
HV+	High voltage supply (2x), connected parallel internally
AO	Regenerative resistor output (shared with MOTOR phase A output)

7.2 Motor connector

Motor connector is a 25 pin female D-Sub connector with four power outputs and one frame ground (FG) pin. Six output pins are connected in parallel for higher current carrying capacity and **maximum current per output pin is 3.3 A**.

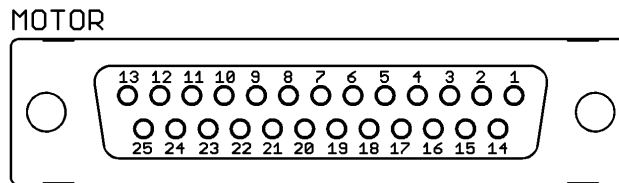

Figure 3: Motor connector pin out (25 pin female D-Sub)

Pin	Description
1 (internally connected to D-Sub metal shells)	Frame ground (FG). Connect to cable shield.
2-7 (internally connected parallel)	Motor phase C output
8-13 (internally connected parallel)	Motor phase B output
14-19 (internally connected parallel)	Motor phase D output
20-25 (internally connected parallel)	Motor phase A output (shared with regenerative resistor output)

The following table summarizes the wiring for different types of motors.

Output pins	AC/BLDC	DC (parallel)	DC	Stepper 2PH	Stepper 3PH
D	Phase W	Armature -	Armature -	Phase A+	Phase A
C	Phase V	Armature +	Armature +	Phase A-	Phase B
B	Phase U	Armature +	Armature +	Phase B-	Phase C
A	Used by optional regenerative resistor	Armature -	Used by optional regenerative resistor	Phase B+	Used by optional regenerative resistor
FG	Motor frame & cable shield	Motor frame & cable shield	Motor frame & cable shield	Motor frame & cable shield	Motor frame & cable shield

Note: in DC motor mode B & C must be wired in parallel.

In parallel DC mode C & B and A & D must be wired in parallel.

7.3 Encoder connector

This is a 15 pin female D-Sub connector for **feedback devices** (*Quadrature encoder, Hall sensors and home switch*).

Encoder

Both **single ended** (TTL or open collector) and **differential** encoders can be used:

- To use **single ended** encoder, connect encoder outputs to positive inputs only and leave negative inputs unconnected.
 - Single ended encoders are not recommended for longer than 3 meter cable length.
- For **differential** encoder, connect positive and negative (inverted) outputs to corresponding input pins.
 - **For long cable lengths** (beyond 3 meters), it may be necessary to **terminate differential pairs with 120 Ohm resistors** (connected from A+ to A-, B+ to B- etc). A 10 nF capacitor can be connected in series with termination resistor to reduce encoder current consumption. Terminators can be soldered inside D-Sub connector housing or connect them externally to EXT connector.

Hall sensors

Optional open collector or TTL Hall sensor (AC & BLDC motors only) can be connected to corresponding inputs or left open if sensorless motor phasing is used (configured from GDtool).

Home switch

Optional *home switch* should be connected between pins 4 and GND. **Contact to other conductors** and machine ground must be avoided.

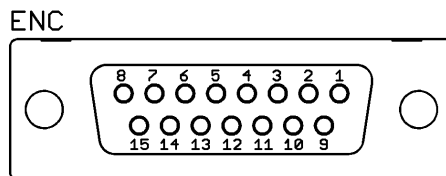

Figure 4: Encoder connector pin out (15 pin female D-Sub)

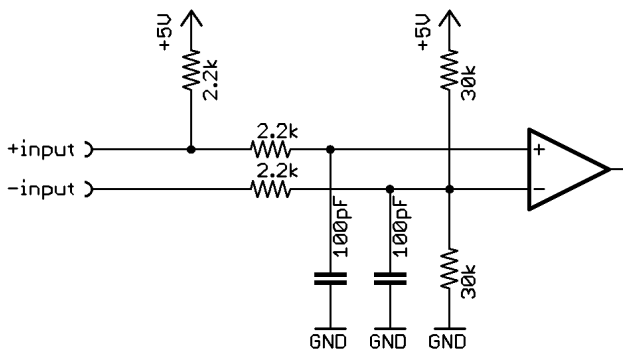

Figure 5: Equivalent circuit for differential inputs (pins 4-7 and 12-15)

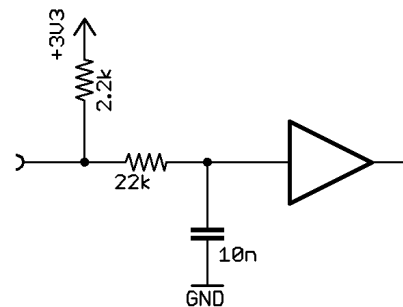

Figure 6: Equivalent circuit for Hall sensor inputs (pins 1-3)

<i>Pin number (signal name)</i>	<i>Function</i>
1 (HALL_W)	Hall input W
2 (HALL_V)	Hall input V
3 (HALL_U)	Hall input U
4 (HOME+)	Home switch input +
5 (IDX+)	Channel Z+ (index)
6 (CHB+)	Channel B+
7 (CHA+)	Channel A+
8 (GND)	GND
9 (FG)	Frame ground (FG), connected internally to D-Sub shells. Connect to cable shield.
10 (GND)	GND
11 (+5V_OUT)	+5V output (encoder power), see electrical characteristics for maximum load
12 (HOME-)	Home switch input - (don't use)
13 (IDX-)	Channel Z- (index)
14 (CHB-)	Channel B-
15 (CHA-)	Channel A-

7.4 CMD connector

This is a connector for optoisolated & non-isolated command I/O. **SPI, step/dir, quadrature, PWM** and **analog** interfaces are brought into this connector. **Pins 1-12 are optoisolated.**

HSIN inputs (pins 3-6) are differential, which can be driven from three kinds of outputs: single ended, differential or open collector. In typical single ended application negative (-) pins are wired to control source ground.

Rest of isolated digital I/O (**pins 7-12**) **share common** voltage levels (IO_COM). If valid output from OUT1 or OUT2 is needed, it is necessary to supply 3 to 5V between pins IO_COM and IO_VCC.

Analog interface pins 13-16 are not isolated and care must be taken when connecting to equipment.

AIN input pins can also be used as configurable **digital inputs**. It is possible to utilize voltage supply pins (13-14) to power external optoisolators that drive AIN inputs as digital circuit.

Note: functionality like **disable input** or **servo ready output** can be configured from GDtool to any unused general purpose I/O. See chapter 10.5 Configurable I/O functions.

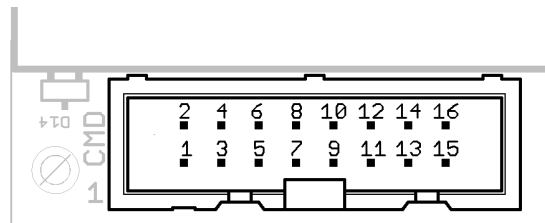
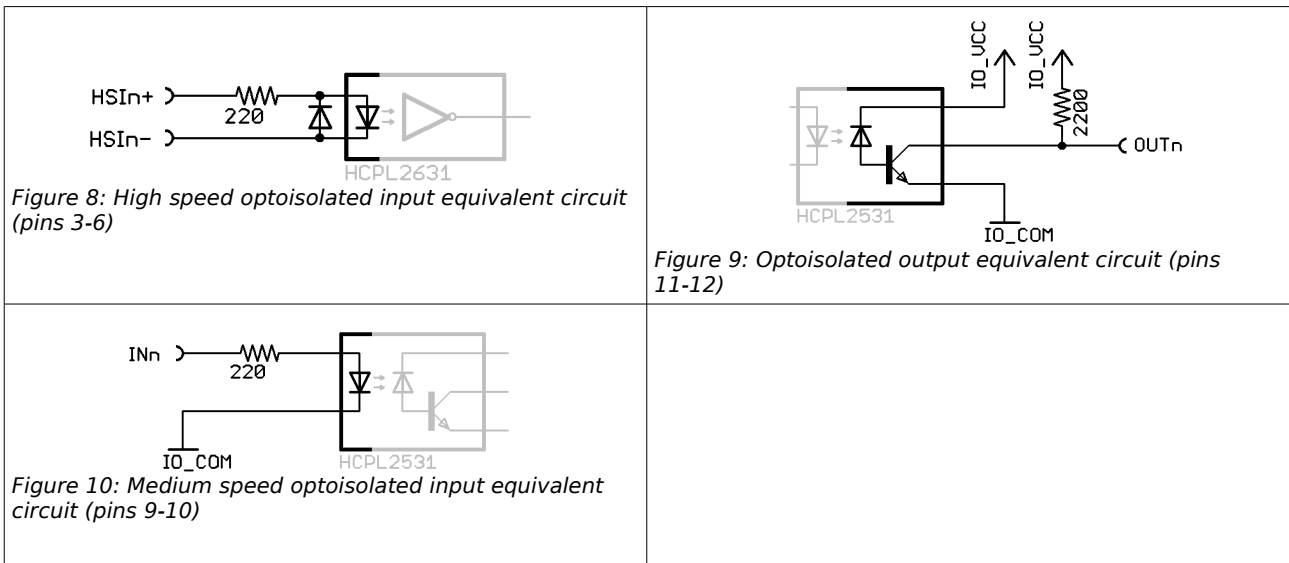

Figure 7: CMD connector (8x2 0.1" centers shrouded header)

Pin number (signal name)	Electrical feature	Functions (slash separated)
1 (NC)	Not connected	Reserved for future use
2 (IO_COM)	Common voltage for optoisolated I/O (0V from controller)	Reference voltage for single ended optoisolated I/O
3 (HSIN1+)	High speed optoisolated input +	Step in / Quadrature A in / PWM in / general purpose input
4 (HSIN1-)	High speed optoisolated input -	Usually connected to controller 0V
5 (HSIN2+)	High speed optoisolated input +	Direction in / Quadrature B in / general purpose input
6 (HSIN2-)	High speed optoisolated input -	Usually connected to controller 0V
7 (IO_VCC)	Voltage supply for isolated output pins (3-5Vdc from controller)	Used to power output optoisolators if outputs are needed
8 (IO_COM)	Same as 2	
9 (IN4)	Medium speed optoisolated input	SPI SCLK / general purpose input
10 (IN3)	Medium speed optoisolated input	SPI MOSI / general purpose input
11 (OUT2)	Medium speed optoisolated output	SPI MISO / general purpose output
12 (OUT1)	Medium speed optoisolated output	General purpose output
13 (GND)	Drive ground (non-isolated)	Used to supply analog input controls like potentiometer
14 (+5V_OUT)	+5V (non-isolated) See electrical characteristics for maximum load	Used to supply analog input controls like potentiometer
15 (AIN1)	Analog input (non-isolated)	Differential analog input + / general purpose digital input
16 (AIN2)	Analog input (non-isolated)	Differential analog input - / general purpose digital input



Note: In the schematics figures the shaded end represents drive logic side, which is insignificant from user's point of view.

7.5 EXT connector

This is a connector for **external LEDs** and **encoder pass-through** signals for external use.

External LED indicators can be installed for example in enclosure front panel. However, optical fiber is recommended since only 2 out of 3 LEDs can be connected to this connector.

Encoder signals are internally connected to ENC connector pins allowing encoder feedback passing to external controller. Also differential line termination resistors can be wired to EXT connector.

All of EXT connector pins are **non-isolated**. External optoisolation may be necessary.

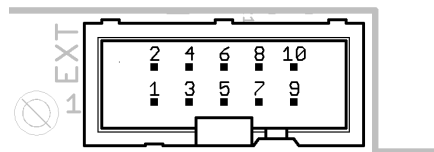

Figure 11: EXT connector (5x2 0.1" centers shrouded header)

Pin number (signal name)	Electrical feature
1 (CHB+)	Connected to ENC pin 6
2 (CHB-)	Connected to ENC pin 14
3 (CHA+)	Connected to ENC pin 7
4 (CHA-)	Connected to ENC pin 15
5 (IDX+)	Connected to ENC pin 5
6 (IDX-)	Connected to ENC pin 13
7 (GND)	Connected to drive ground
8 (+5V_OUT)	+5V output (see electrical characteristics for maximum load)
9 (LED3)	LED3 signal, +5V=led on, 0V=led off. Output resistance 220 Ohms.
10 (LED2)	LED2 signal, +5V=led on, 0V=led off. Output resistance 220 Ohms.

8. Installation notes

8.1 Wiring

Typical installation of drives in metal enclosure is presented in the figure below.

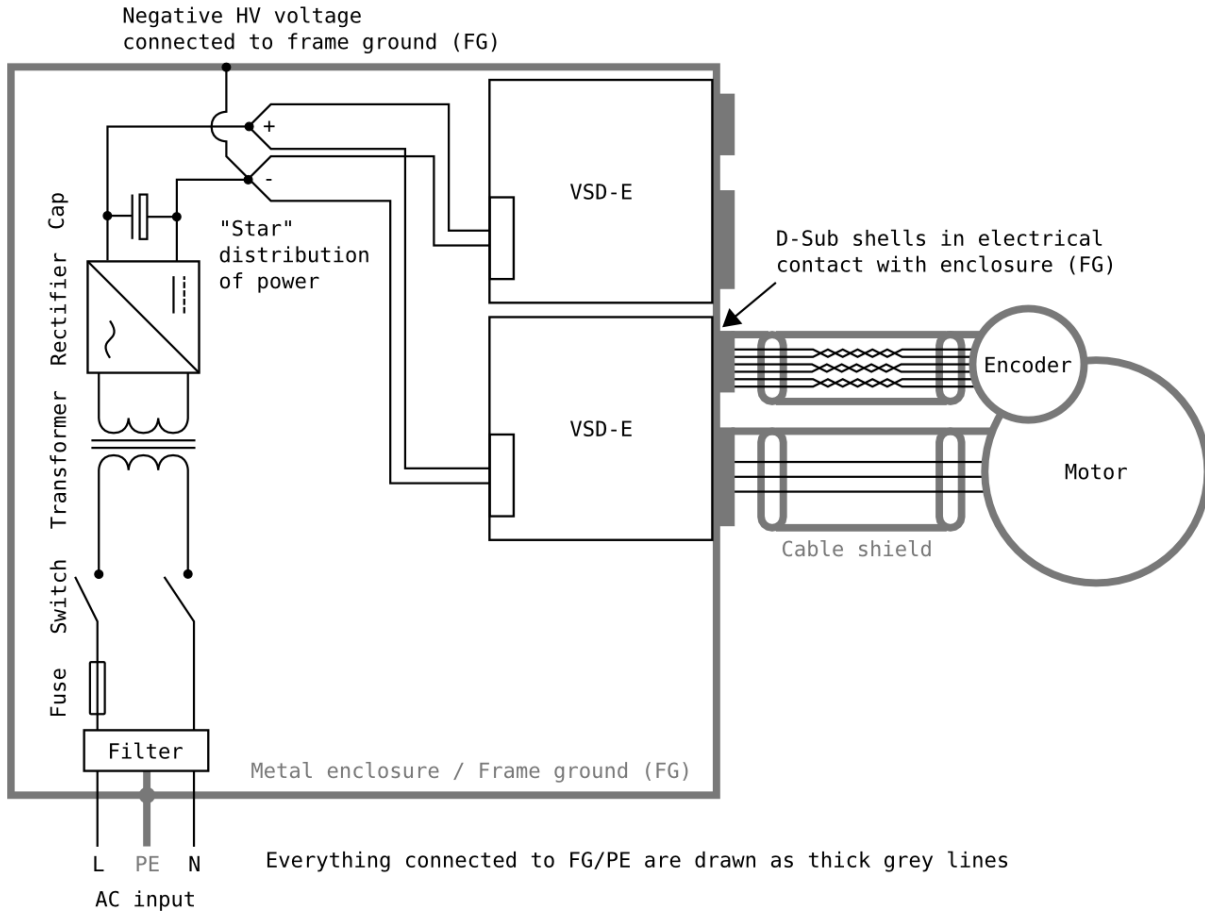

Figure 12: Suggested VSD-E installation scheme

8.2 Grounding

Drive has two separate grounds for separate purposes which are named as **GND** (ground) and **FG** (frame ground). **GND** is the electrical 0V potential shared with power supplies and all connector pins labeled as "GND". Connect GND to power supply 0V terminal.

FG is the ground for EMI shielding which is located in D-sub connector metal shells and D-sub connector pins labeled as "FG". **FG** and **GND** are electrically floating against each other but are connected by EMI suppression capacitor inside drive. **Make sure that D-sub shells make electrical contact to enclosure metal and cable shields are connected to FG** through corresponding pins or D-sub shells.

8.3 Shielding

Shielded cables are required to avoid interference problems and data errors in communication cables. Connect cable shields to **FG** only from drive end.

If a compliance for CE or UL is required, the system should be characterized as whole in appropriate test arrangements.

Noise shielding tips

- Minimize the parallel running distance between HV+ and GND power wires to minimize the conductor loop area. In other words, **twist the HV+ and GND wires together** or use **cable with two conductors**
- If **wiring distance** from drive to power supply capacitors is **greater than 30 cm** and configured peak current **greater than 5A**, it may be necessary to connect a 330 μ F/100V capacitor directly to POWER connector terminals (between GND and HV+ pins).
- Always **use separate cables** for motor and encoder, no matter how small the motor is. In shared cable, high dV/dt of motor outputs may easily couple to encoder wires causing errors.
- In **some cases**, it may be more optimal to connect encoder cable shield to GND instead of FG. In such case, shield must contact single GND pin only and **avoid any other contacts** (i.e. motor chassis must be isolated from encoder cable shield)

8.4 Protection

VSD-E has on board fuses for HV bus. If protection also against **wiring failure** is required, then an additional fuse after power supply is recommended.

VSD-E has been supplied with 20A slow blow fuse which is adequate for most cases. In maximum power DC motor operation a higher rating fuse may be necessary (supplied by user). User may also replace default fuse to a smaller one if lower protection threshold is desired.

For additional motor protection, fuses can be added in series to motor phase wires. In three phase motor fusing two leads should be enough in most cases and for DC motor one lead will be sufficient protection.

It is recommended to **do initial testings with reduced HV bus voltage and with lower current fuse rating**.

8.5 Cooling

Additional cooling should be used if aluminum plate temperature rises above 70° Celsius during intensive load. Improved cooling can be achieved generally by two ways:

- Adding forced air flow by using a dust filtered fan
- Mounting a heat sink on aluminum plate by using thermally conductive epoxy adhesive. Two heat sinks with size of 40x40x10...30 mm will fit on VSD-E surface.

The most efficient cooling can be achieved by combining both methods.

Typical cooling requirements

VSD-E can be typically used without additional heat sinks and fans when **average output current is below 4 Amps** and surrounding air temperature below 35°C.

VSD-E can be typically **stressed to its maximum ratings** without additional heat sinks when moderate air flow is passing by the drive surface (fan cooling) and cooling air temperature is below 30°C.

Drive's built in over temperature protection will shut down power stage and let motor free-wheel if surface temperature rises above 70°C. It is recommended to **do careful testing at elevated ambient temperatures** before making conclusion of system cooling sufficiency.

8.6 Regenerative resistor

Regenerative braking resistor can be installed to **prevent HV bus voltage increase and overvoltage faults** during motor deceleration. The problem exist when significant masses are decelerated which will cause supply voltage pumping as motor acts as a generator.

VSD-E drives uses the **A output** phase of power stage to drive current thru regenerative resistor when HV bus voltage gets close to, or exceeds, configured upper limit of HV bus voltage. Regenerative output option is **available only** in motor modes which don't occupy A output. For supported modes, see chapter 13.1 Motor configurations & output currents.

Note: it is usually enough to have **one** regenerative resistor in multi axis system unless required braking current is higher than 10 Adc.

Sizing regenerative resistor

The current through resistor **must not exceed 10 Adc**, so the **minimum allowed** resistance becomes

$$R_{min} = \frac{HVbusUpperVoltageLimit}{I \cdot A}$$

Dissipated power increases in **power of two** as voltage increases. Resistor peak power becomes

$$P_{min} = \frac{HVbusUpperVoltageLimit^2}{R_{selected}}$$

Since **braking is momentary**, resistor power rating can be often selected below calculated peak power.

Sizing example: We have 80 Vdc bus voltage on medium size machine where we want to size a braking resistor. The *minimum* allowed resistance becomes $80V/10A=8\Omega$ which would equal about $80V^2/8\Omega=800$ Watts of braking power.

Since typical systems don't need so much braking power as we calculated, we choose resistance of 47Ω which equals power of 136 Watts. Resistor with power rating of 100 W should be safe choice in this example.

Connecting resistor

Regenerative resistor should be connected to **POWER connector** between pins **AO** and **GND**. Shielded cable is recommended if longer than 10 cm wires are being used.

Especially overloaded resistor may get **extremely hot** (over 200°C possible). It is absolutely necessary to place the resistor away from any heat sensitive surfaces such as wires and circuit boards. Cooler operation can be achieved by choosing higher power rating resistor.

Activating regenerative resistor doesn't need any further drive configuration. VSD-E will attempt controlling **AO** always as regenerative resistor whenever it is not occupied by motor windings.

Warning: never connect regenerative resistor if all 4 power output phases are used by motor!

8.7 Connection to motor & controller

The figure below illustrates **VSD-E wiring** to surrounding system. Since CMD port pins are configurable, please refer to chapters 7.4 (p. 13), 10.5 (p. 27) and 12 (p. 29) about functionality of digital I/O.

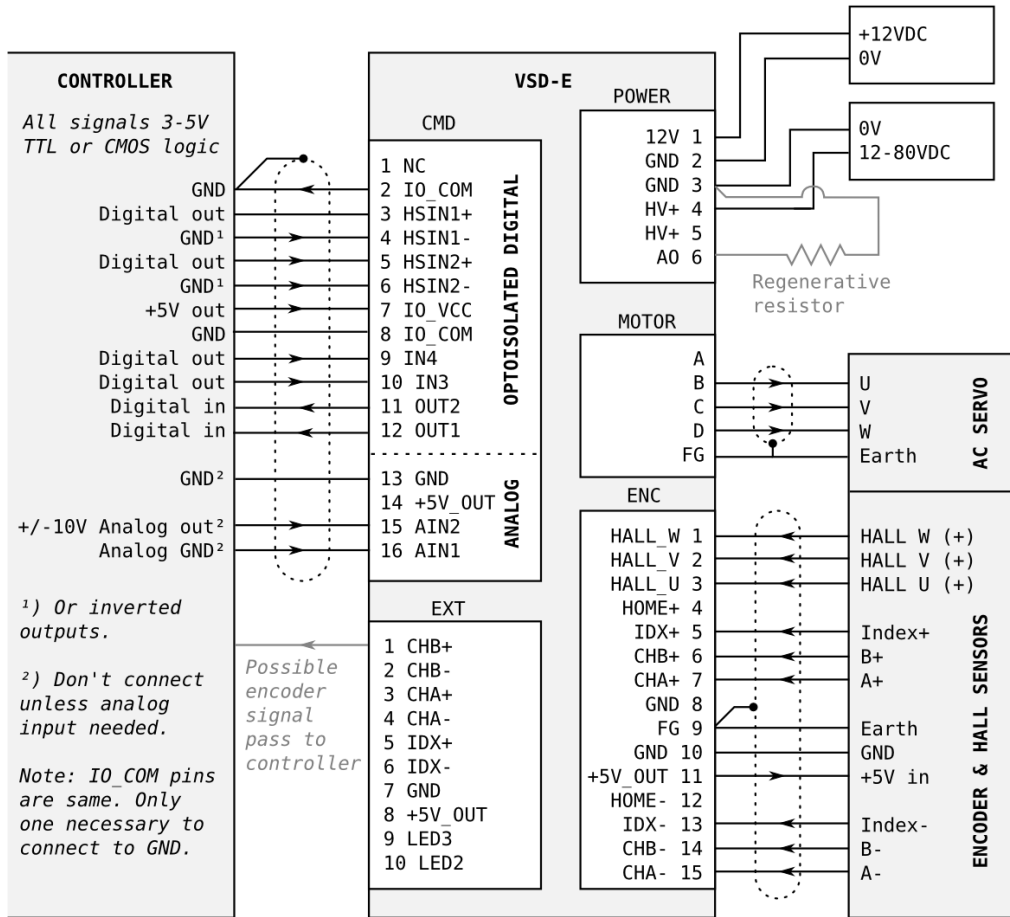

Figure 13: Typical controller and motor wiring. This configuration uses AC motor with Hall sensors. All of connections are not needed if certain features are not used.

9. Power supply

VSD-E runs on unregulated or regulated **isolated power supply** which means that there is no galvanic or conductive connection between the AC mains and DC bus. A linear transformer based PSU is preferred over switching mode power supplies (SMPS) for servo systems since transformers are capable of delivering high peak output power just like motors are.

For logic power, a separate regulated 12V power supply is required.

Warning: This is only a very brief guide of powering the system in basic cases. An experienced electrician should always be consulted when designing or building power system.

Pay attention to *RMS* and *peak* terms in this text. Mixing these can lead to unpredictable results.

9.1 Basic guide for sizing linear PSU components

In short, PSU should be sized so that it **does not overload or overheat** during any condition in machine use. Since servo systems typically have greatly varying load, it might be necessary to find effective power consumption by measuring *RMS power* consumption of the system during at least 10 second period of heavy use.

If measurements can't be done, then maximum RMS power load can be estimated roughly by summing rated power values of motors in the system. However, **in typical machines the average power consumption is significantly less than summed motor power.** Motor power consumption is proportional to product of actual torque and speed (Power=Speed*Torque). Following chart gives rough figure of power requirement in motion systems:

	<i>Moving slowly</i>	<i>Moving fast</i>
<i>Producing low torque</i>	Very low power consumption	Low to medium power consumption
<i>Producing high torque</i>	Low to medium power consumption	High power consumption

Transformer

Transformer size can be selected after RMS power demand is determined. One should choose transformer with a safety margin since VA rating of transformers do not equal to RMS watts in linear PSU. For example, if RMS power consumption is 200 Watts, then using of at least 300 VA transformer is recommended.

Transformer primary voltage should match with the voltage of AC mains network of your area. Secondary voltage should be about 1.41 times *smaller* than desired DC bus voltage. To convert DC bus voltage to transformer secondary voltage, use equation

$$U_{secondary} = \frac{U_{DC}}{1.41}$$

Bridge rectifier

Bridge rectifier should be able to handle *peak current* of rectification. Typically a very high peak currents can be present during power-up and during motor peak loads. Use at least **safety factor of 4** when choosing rectifier current rating compared to RMS current. Rectifier may need cooling to prevent overheating damage.

Capacitors

VSD-E HV bus accepts unregulated power up to 50% ripple voltage, however designing a supply with maximum of 10 to 20% ripple is recommended. **To solve required power supply filter capacitor size, use equation**

$$C = \frac{I_{load} * T}{U_{ripple}}$$

where C is required capacitance in Farads, I_{load} is the *peak load current*, T cycle time of rectified voltage and U_{ripple} is the desired maximum ripple voltage.

Calculation example

1. If you need 70 Vdc DC bus voltage and you choose to design for 20% ripple, then $70 * 20\% = 14$ V ripple (U_{ripple}) voltage is allowed.
2. If you are using full-wave rectifier for 50 Hz mains voltage, then cycle time T is 0.01 seconds
3. If your peak power load is 500 Watts, then I_{load} becomes $500W / 70V = 7.2$ A
4. By substituting these values in equation above, the minimum required capacitor value becomes

$$C = \frac{I_{load} * T}{U_{ripple}} = \frac{7.2A * 0.01s}{14V} = 0.00514 \text{ Farads} \approx 5000 \mu F$$

Note: capacitor **voltage rating should be at least 20% greater than rectified DC bus voltage** to provide sufficient safety headroom.

Warning: during motor deceleration, drive pumps energy back from kinetic energy to power supply which leads to capacitor voltage rise. Power supply capacitors may be charged up to drive's over voltage fault level (up to about 100 Vdc). See chapter Regenerative resistor on page 18 for more information.

Fuses

Use slow-blowing fuses that can withstand the peak currents required by drive under all normal load conditions. Finding optimal fuse size may require experimenting.

9.2 Example circuits

Following figures show simplified PSU cases. Line filters may be required before AC input to comply with local EMI regulations. Note that fuses are optional with VSD-E.

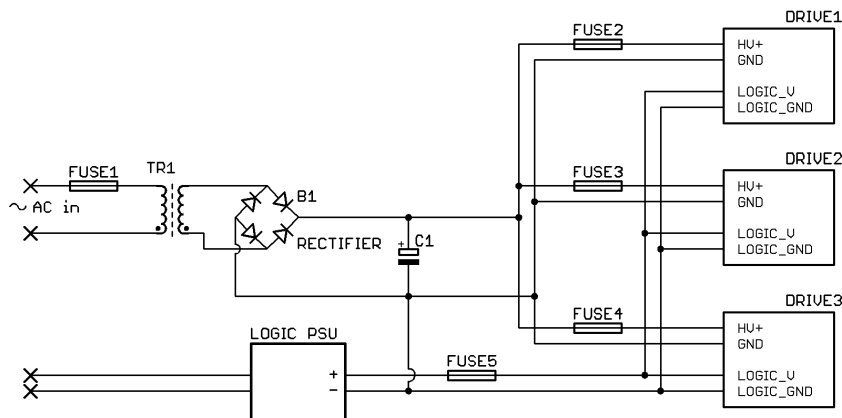

Figure 14: Simple transformer based linear PSU up to about 500 Watts

Drive can be powered also by a switching mode power supply (SMPS). A diode (D1) and capacitor (C1) are required to prevent regenerative current from flowing back to SMPS.

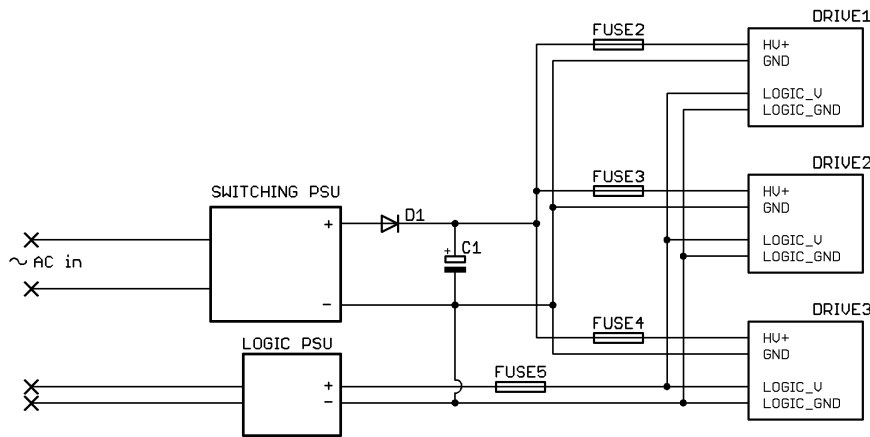

Figure 15: Switching mode power supply (SMPS) circuit

9.3 Power-up sequence

Before powering up the first time, it is **highly recommend** to check all connections for correctness. It is advised to use multimeter to make sure there is no short circuits in connections.

Powering up

Powering up logic and HV bus can be done in **any order** or simultaneously. If logic power is being connected first, drive will wait for HV bus rise before initiating motor control.

Power rise times

A very fast rise time on HV bus voltage must be avoided to prevent damage on power components. Don't place a mechanical switch or relay right before HV inputs. Instead place such devices before filtering capacitors or transformer. HV bus rise time should be longer than 5 milliseconds.

If **logic voltage** rise is too slow, drive may generate an error status, which can be reset by power cycling (see chapter *LED status indicators*). Logic voltage rise should be faster than 50 milliseconds.

Delaying power-up

If necessary, drive motor control start-up **can be delayed** by driving logic 1 value to user configured **disable input** while power supplies are switched on. Drive begins motor initialization after input value is released to logic 0. Disable input must stay low during whole initialization process (i.e. while blue led *not* constantly on). If drive gets interrupted by disable signal during initialization process, an **init fault** condition will occur. Init fault can be cleared only by power cycling.

10. Drive logic

This chapter describes the internal operation of VSD-E drive.

10.1 Main operation modes

Logic levels on CMD port **IN3** and **IN4** during logic power rise will determine the operation mode for drive. Three modes are possible: *SPI disabled mode*, *SPI communication mode* and *bootloader mode*.

The following table summarizes the modes of operation.

Mode #	Mode	Description	I/O availability
1	SPI disabled	<ul style="list-style-type: none"> ● This is a motor control mode ● SPI communication is disabled ● Drive accepts pulse input commands ● Drive accepts analog commands ● GDtool cannot communicate with drive 	All CMD port I/O pins are usable & configurable by user.
2	SPI enabled	<ul style="list-style-type: none"> ● This is a motor control mode ● SPI communication is enabled ● GDtool can configure the drive ● Drive accepts pulse input commands ● Drive accepts analog commands 	CMD port inputs IN3 and IN4 and the output OUT2 are occupied by SPI bus. These I/O's cannot have other functions while SPI mode is on.
3	Bootloader	<ul style="list-style-type: none"> ● Motor control disabled ● GDtool can upgrade the firmware 	No user I/O

In short, the only difference between modes 1 & 2 is that three pins of CMD port pins will have different functions. If necessary, user can disable mode 1 completely by selecting "Force SPI" mode from GDtool. The rest of this chapter will concentrate describing modes 1 & 2.

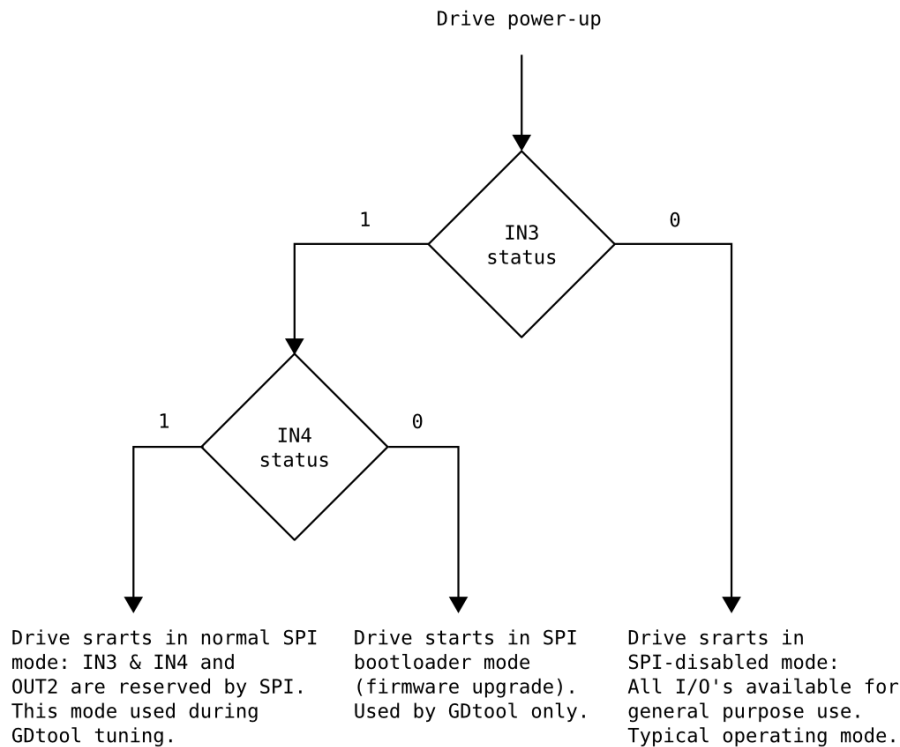

Figure 16: Operation mode selection during logic voltage rise versus CMD port IN3 & IN4 logic statuses

10.2 Input command processing

Trajectory planner

Trajectory planner is an input filter that **limits commanded acceleration and velocity** to user specified levels. Trajectory planner works in position & velocity modes.

User may set different acceleration and velocity limits for homing operation and separate velocity limit for error recovery moves.

By default acceleration limit is not active in pulse input modes since usually acceleration limiter is implemented in controller. Acceleration limit in pulse modes can be enabled from GDtool settings. It is advisable to have only one acceleration limit in system since double limiting may cause significant motion lag.

Input scaling

VSD firmware has adjustable **input multiplier and divider** which allow freely adjusting the scaling ratio of input torque, velocity or position commands. Total scaling ratio is determined by equation

$$\text{Scaling} = \frac{\text{Multiplier}}{\text{Divider}}$$

For example scaler can be used to get around of possibly limited output pulse frequency of controller (i.e. in step/dir mode) while using high resolution encoders. Even when using scaling, full encoder resolution is preserved internally to maximize motor performance.

Input smoothing filter

VSD firmware incorporates a sophisticated digital filter for input commands **reducing jerkiness and increasing motion smoothness**. Input filtering can be enabled or disabled from GDtool.

It is advisable not to use filtering when position or velocity feedback loop is located outside drive as filtering adds small delay to input.

10.3 Motor control algorithms

VSD-E motor control is based on **cascaded controllers** (a.k.a series connected) where each controller does only one thing, but does it well. There are separate controllers for **torque, velocity** and **position**.

For example a velocity controller outputs torque command that is fed to torque controller and position controller outputs velocity command that is fed to velocity controller. Cascaded structure leads to the highest obtainable control bandwidth & stiffness while easing the motor tuning since each controller block can be kept simple and easy to tune in.

For controller tuning guide, read our GDtool user manual.

Torque controller

Torque is proportional to motor current, so in other words torque controller is a current controller. Torque controller measures actual phase currents and compares them against commanded current and feeds the difference to PI gain block. Output of torque controller is fed to power stage voltage commands (or output PWM duty cycle ratios) that is needed to achieve the desired current.

For AC motors VSD-E implements sinusoidal field oriented current control which provides the optimal torque & response speed in all conditions.

Velocity controller

Velocity controller uses velocity measured from encoder and compares it against target velocity

command. The measured velocity vs. commanded velocity differential is fed to a PI controller that outputs torque command.

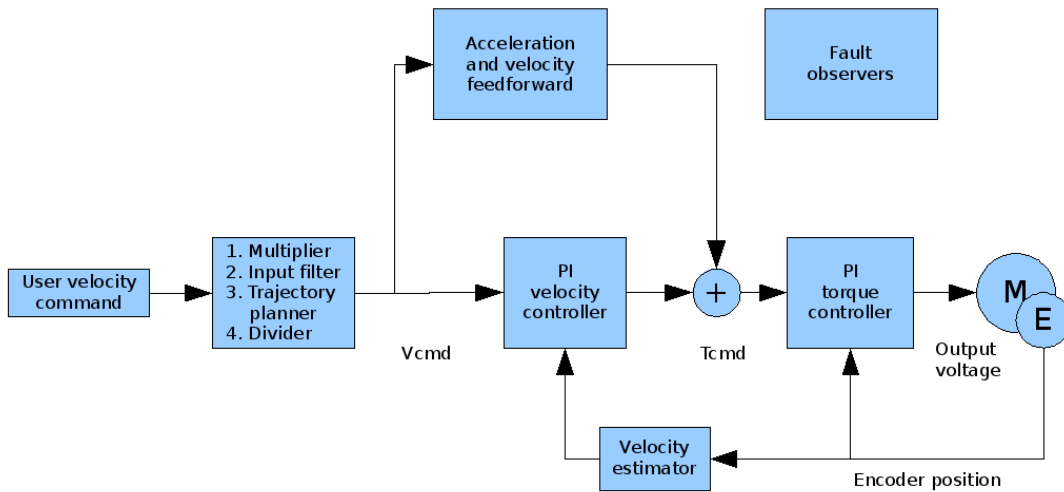

Figure 17: Overview block diagram of PI type velocity controller.

Position controller

Position controller uses measured position value from encoder and compares it against target position command. The calculated position error is fed to a simple P controller (proportional gain) that outputs velocity command. This controller type is also known as PIV controller.

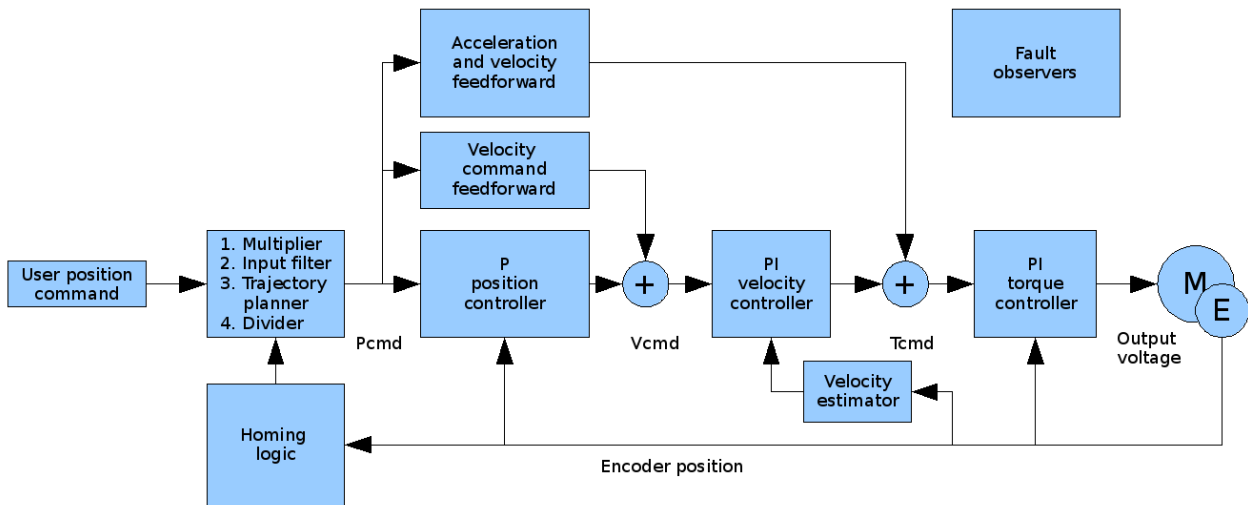

Figure 18: Overview block diagram of PIV type position controller.

Alternative form of position control is PID controller, which is also available as option in GDtool. This mode uses traditional PID controller to calculate torque command directly from position error signal.

Feedforwards

In velocity & position control it is beneficial to use available target velocity and acceleration information to calculate estimates of needed torque commands. The goal of feedforward is to produce as good as possible torque output signal before any error is formed. This greatly reduces time to respond in commands.

Feedforward is based on known behavior of machine parameters such as mass and friction.

10.4 Limits & fault monitoring

The following table summarizes available settable operation limits in VSD-E.

Limit	Range	Function
Peak current	From 0 up to 40000 mA. Limitations apply in certain modes, see chapter 13.1.	Motor peak current limitation.
Continuous current	From 0 up to 14000 mA. Limitations apply in certain modes, see chapter 13.1.	Motor continuous current limitation.
Homing current	From 0 up to 14000 mA. Limitations apply in certain modes, see chapter 13.1.	Motor current limit during homing motion.
Phase search current	From 0 up to 10000 mA. Limitations apply in certain modes, see chapter 13.1.	Motor current during AC/BLDC/Stepper phase search (few seconds during start-up). Not needed if Hall sensors are present.
Thermal time constant	30 to 7200 seconds	Thermal limiting calculates motor temperature rise as function of I^2t . This will limit output current to <i>continuous current</i> level if thermal model indicates maximum motor temperature.
Velocity	1 to 32767 (internal units)	Velocity limit in position & velocity modes. Separate velocity limit can be set for homing motion.
Acceleration	1 to 32767 (internal units)	Acceleration limit in position & velocity modes. Separate acceleration limit can be set for homing motion.
Recovery velocity	1 to 32767 (internal units)	Velocity limit for error recovery motion (position mode only).
Position	+/- 2 000 000 000 counts	Position limits in encoder counts which becomes active after successful homing. For position mode only.
Torque command bandwidth	100 to 3300 Hz	This is a low pass filter for torque command. Rejecting higher frequencies may provide quieter operation and avoid mechanical resonance.

The following table summarizes protection functions in VSD-E.

Fault	Range	Function
Overcurrent	From 0 to max peak current+3A	Overcurrent fault is generated & drive stopped if measured phase current exceeds the configured value
Overvoltage	20 to 85 Vdc	Upper limit for allowed HV bus voltage. Overvoltage fault is generated & drive stopped if limit exceeded.
Undervoltage	10 to 80 Vdc	Lower limit for allowed HV bus voltage. Undervoltage fault is generated & drive stopped if limit exceeded. On power-up drive will also wait for voltage to rise above this limit before initiating motor control.
Following error	0 to 16383 encoder counts or speed error	A following error fault is generated & drive stopped if motor position or velocity deviates more than specified limit from commanded target value.
Motion error	0 to 16384	This generates fault & stops drive if enough motor speed is not detected at certain torque command level. This can provide protection for: <ul style="list-style-type: none"> ● DC motor runaway ● Mechanical blocking ● Encoder failure Motion error typically reacts faster than the <i>following error</i> .
SPI watchdog	0 to 65535 PID cycles	Communication fault is generated & drive stopped if SPI communication is lost for given amount of time.
SPI communication error	Invalid command, invalid parameter or CRC error	Communication fault is generated & drive stopped if an error is detected in SPI command.

Short circuit	> 60 A (fixed)	A fast reacting protection for output short circuit .
Overtemperature	> 70 °C (fixed)	Generates overtemperature fault & stops drive if measured PCB temperature exceeds a fixed value.
Program & hardware	Internal code & data integrity checking	Generates a fault & stops drive if memory corruption or hardware fault is detected in DSP. May be caused by too low logic supply voltage or slow rise time of logic supply.
Analog input overvoltage	> 11 V or < -11 V	Diode clamps will protect from overvoltage at analog inputs .
Reverse polarity	HV+ or logic power input	Diode clamped (HV) and series diode polarity protections for voltage inputs against reverse input voltage polarity.

10.5 Configurable I/O functions

All physical inputs and outputs that aren't occupied by fixed functionality, such as step/dir inputs or SPI bus, can be **configured to suit user's needs**.

General purpose OUTPUT pins

Physical outputs (up to 2) can be configured to display any internal status or fault register bit. For example, useful output signal may be chosen from following table

Source signal	Description
Fault stop	This becomes logic 1 if drive is stopped on any fault
Follow error warning	This becomes logic 1 if position or velocity following error is greater than 1/8 of configured follow error fault level
Target reached	This becomes logic 1 if motion command has reached its target . (i.e. when positioning travel is complete after acceleration, and deceleration).
Servo ready	This becomes logic 1 when servo is ready for user commands
Homing status	This becomes 1 when homing sequence is running
Home switch status	This represents the digital status of home switch input in ENC connector

General purpose INPUT pins

Physical inputs (up to 6) can be configured to operate internal functions described in the following table.

Function	Description
Disable drive	If this input has logic value 1, drive will disable motor control and let motor free-wheel.
Clear faults (edge sensitive)	Rising edge in this input will clear active faults to allow continuing operation of drive.
Start homing (edge sensitive)	Rising edge in this input will start homing sequence.
Run indexer sequence	Drive can contain multiple stored motion sequences that can be executed by user defined input signal. Rising edge of input will start motion sequence .

Multiple functions can share one input pin. This makes it possible to share single pin for both *disable drive* and *clear faults*.

11. LED status indicators

The VSD-E has three LEDs (**green**, **red** and **blue**) which have combinations of blinking and steady states to indicate current status or fault. Blinking sequences have varying styles to make them easier to remember and distinguish later. Drive statuses versus led statuses are described in the table below.

Only the fault that **occurred first** is displayed in LED indicators. Other active faults (that can be viewed in GDtool) might have followed consequently as “chain reaction” after first one occurred.

No	Green LED1	Blue LED2	Red LED3	Status	Motor output on
1	Blink	Off	Off	Drive stopped until next logic power cycle. Occurs if drive hasn't been configured (powered first time) or if motor type was modified in configuration.	No
2	Blink	Blink	Off	Drive initialization or AC motor phase search in progress	Yes
3	Off	On	Off	Enabled and running	Yes
4	Blink	On	Off	Recovering from follow error or from disabled state	Yes
5	Off	On	Blink	Input motion command range error	Yes
6	Off	Off	Blink	Following error	No
7	Blink	Off	Blink	Motion error. Motion stalled or encoder failure. See chapter 10.4.	No
8	Off	Blink	Off	Disabled by user	No
9	Blink	Blink	On	Init or AC motor phase search failed. Possibly too low voltage.	No
10	Off	Off	On	Other fault, get details via SPI bus or contact us for support.	No
11	Off	Blink	Blink	HV bus over voltage or under voltage fault	No
12	Blink	On	Blink	Overcurrent (caused by bad tuning) or short circuit fault. With DC motors also faults if output phases are not properly wired in parallel.	No
13	On	Blink	Blink	Overtemperature	No
14	Blink	Blink	Blink	Communication error, invalid command or invalid command parameter. Check cabling & jumper settings. Electrical noise may also cause this.	No
15	Blink	On	On	Internal error, possibly caused by logic undervoltage or too slow logic voltage rise time. If troubles, contact us for support. See also #11.	No
16	On	Off	Blink	Drive ready for firmware update	No
17	Off	Blink	Blink	Firmware upgrade failed, cycle power and try again	No
18	Off	Blink	Blink	Blinking very slowly. Memory checksum error, install upgrade firmware again or contact us if problem stays	No

For troubleshooting, please see chapter 14 *Troubleshooting* and chapter 10.4 *Limits & fault monitoring*.

12. Physical command inputs

The VSD drive supports multitude of input command modes to realize maximum versatility.

The SPI input mode is referred as “**SPI input**” while all other input modes are referred as “**pulse inputs**”. Pulse inputs include Step/dir, Quadrature, PWM, Indexer and Analog inputs.

12.1 SPI input

SPI input allows operating drive the most flexible way from programmable controllers. SPI input format and commands will be specified additional documentation.

12.2 Step & Dir inputs

Step/dir position control

In step/dir position mode the drive will listen pulse commands from CMD port **HSIN1** & **HSIN2** pins. Drive will increment position target value when positive rising edge is detected at HSIN1. Direction of incrementation will be determined by the logic status of HSIN2 during rising step edge. Status of HSIN2 should be pre-set at least 150 nanoseconds before step edge.

In torque mode step/dir works same in the same manner: torque target will be incremented or decremented by step signals.

Step/dir velocity control (pulse frequency input)

If drive is configured for velocity control mode, the step/dir inputs will act as pulse frequency input where step pulse frequency will determine target speed of motor. Direction input may be used to change rotation direction. With 1:1 scaling, input frequency will match encoder count frequency.

12.3 Quadrature inputs

In quadrature input mode the drive listens quadrature signals from CMD port **HSIN1** & **HSIN2** pins. Quadrature signal is similar to quadrature encoder signals which is typically used in applications like encoder follower and slave axis.

In all drive modes (position, velocity and torque) quadrature input will increment or decrement target value depending on input signal direction.

12.4 PWM & Analog inputs

PWM input

VSD-E has PWM input (CMD port **HSIN1**) that is controlled by a signal where duty cycle ratio of logic 0 and logic 1 will determine amplitude of command.

Since PWM input doesn't have polarity, the input signal will be always positive. Zero level is at 50% duty cycle, negative when duty cycle is below 50% and positive when above 50%.

0% and 100% duty cycles are theoretical references only and in practice cannot be used. Drive sets output command value to zero if PWM input is not detected (i.e. no logic transitions pass through optoisolator). To stay in **valid duty cycle range**, limiting input to 5%...95% range is recommended.

Analog input

VSD-E has two analog inputs (CMD port **AIN1** & **AIN2**) which will measure input signal differentially. Both inputs have nominal input range of +/- 10 Volts and output command is obtained by difference of input pin voltages. Positive 10V difference (i.e. AIN1=10V AIN2=0V) will equal 100% command and negative 10V difference (i.e. AIN1=-9V AIN2=1V) will equal -100% command. No difference will equal 0% command (AIN1=AIN2).

Analog input offset & scaling can be altered for example to achieve 0.5 V analog input with 2.5 V zero level.

PWM & Analog command scaling

- In **torque mode** the torque command will be proportional to peak current configured by user in GDtool. I.e. with **1/2** input amplitude (equals 75% PWM duty cycle or 5V voltage difference) the output current will be 1/2 of motor's peak current.
- In **velocity mode** the velocity will be proportional to velocity limit configured by user in GDtool. GDtool. I.e. with **-1/2** input amplitude (25% PWM duty cycle or -5V voltage difference) the output speed will be 1/2 of velocity limit in reverse direction.

The default **scalings can be adjusted by user**. Scaling sensitivity can be altered by adjusting GDtool input scaling (multiplier/divider) just like in other modes. User may also eliminate possible input signal offset by adjusting PWM/Analog input offset parameter in GDtool.

12.5 Indexer inputs

Drive can be configured as indexer device, where drive executes preprogrammed position, velocity or torque sequences by simple logic level pulse to any user configurable input. Multiple sequences can be stored in memory and sequence activation inputs can be chosen by user.

Note: Indexer operation is not yet supported by GDtool software. Indexer will be available in future releases.

13. Motor compatibility

This is a short guide for determining whether or not a motor is suitable for VSD-E.

Motor type must be one of the following (rotary or linear):

- Permanent magnet *brushed* DC
- Permanent magnet *brushless* DC (BLDC)
- Permanent magnet AC
- 2 or 3 phase *stepping* motor (3, 4,6 and 8 wire motors)

Servomotors must be equipped with an quadrature/incremental **encoder** with **differential** or **single-ended** (open collector or TTL) outputs (see chapter *Encoder*). Stepping motors can be operated with or without encoder.

Encoder notes:

- 2 channel *encoder* is enough for all motor types
- *Index* channel is not required but is supported for precise homing
- *Hall* or *commutation* sensors are not required but are supported for AC/BLDC motors
- Suitable encoder resolutions are from about 100 PPR to 20000 PPR (pulses or lines per revolution)

Motor **voltages** and **currents** can introduce some limitations to motor output speed and torque but *does not cause unsuitability*.

- **Motor voltage** is the limiting factor for maximum **speed**. For example, if you have a 100 VDC brushed DC servo motor and run it at 70 VDC using VSD-E, then you can expect to get a speed of $88\% \cdot 70V / 100V = 61\%$ of motor's rated speed. 88% comes from VSD-E effective voltage swing at power outputs (see *Electrical specifications*).
- **Motor current** is the limiting factor for maximum **torque**. For example, if you have motor rated for 20A DC and drive's maximum output is 10A DC, then you get 50% of the rated torque.

VSD-E has dual range current sensing (HDRT, High dynamic range torque control) which makes it suitable also for very small motors, such as ones with rated current around 100 mA.

Note: **200 VAC AC servo motors** would reach about 20-30% of their rated speed on 80 VDC drive supply.

13.1 Motor configurations & output currents

The following table summarizes **VSD-E** output capabilities in different motor modes.

Configuration	Continuous current (DC or peak of sine)	Peak current (DC or peak of sine)	Regenerative resistor output	Remarks
AC servo motor	10 A	20 A (15A if >55°C)	Yes	Sinusoidal commutation
BLDC servo motor	10 A	20 A (15A if >55°C)	Yes	Trapezoidal commutation
DC servo motor	10 A	20 A (15A if >55°C)	Yes	
DC servo motor (parallel connection)	14 A	40 A (30A if >55°C)	No	
2 phase stepper	7 A	20 A (15A if >55°C)	No	3 modes possible: - Open loop - Encoder assisted - Closed loop servo
3 phase stepper	10 A	20 A (15A if >55°C)	Yes	3 modes possible: - Open loop - Encoder assisted - Closed loop servo

The following table summarizes **VSD-XE** output capabilities in different motor modes.

Configuration	Continuous current (DC or peak of sine)	Peak current (DC or peak of sine)	Regenerative resistor output	Remarks
AC servo motor	14 A	20 A (15A if >55°C)	Yes	Sinusoidal commutation
BLDC servo motor	14 A	20 A (15A if >55°C)	Yes	Trapezoidal commutation
DC servo motor	14 A	20 A (15A if >55°C)	Yes	
DC servo motor (parallel connection)	18 A	40 A (30A if >55°C)	No	
2 phase stepper	10 A	20 A (15A if >55°C)	No	3 modes possible: - Open loop - Encoder assisted - Closed loop servo
3 phase stepper	14 A	20 A (15A if >55°C)	Yes	3 modes possible: - Open loop - Encoder assisted - Closed loop servo

Note: motor current limits can be adjusted by 1 mA resolution

Note: drive will automatically limit maximum peak currents if surface temperature exceeds **55°C** (see Peak current column).

14. Troubleshooting

I'm getting overcurrent faults

Overcurrent fault may be caused by following reasons:

1. *Measured motor current exceeds fault current level* (configured in GDtool)
 1. Check that configured fault current level is at least 10% greater than configured peak current
 2. Check that torque controller does not have overshooting step response (see GDtool manual)
2. In DC motor mode output phases may not be properly connected parallel
3. Short circuit

If drives are properly configured, they will never generate unexpected overcurrent faults.

I'm getting following error faults

Measured motor position or velocity differs more than user specified limit from *target position or velocity*. Try increasing follow error limit or adjust feedback gains and trajectory planner limits to reduce following error.

I'm getting overvoltage or undervoltage faults

Measured HV bus voltage is not within user specified fault limits. Most common reasons include:

- Regenerative supply pumping. During motor braking supply voltage tends to increase as motor acts as generator. To verify this, attach voltmeter to PSU to check voltage during fault. To prevent this, use regenerative resistor (see chapter 8.6 Regenerative resistor).
- Supply voltage gone below lower voltage limit. This may be caused by undersized power supply.

I'm getting SPI communication errors

This is most likely caused by electrical interference. Check correctness of shielding and grounding of the system and try locating the interference source.

15. Mechanical dimensions

The drawings are for VSD-XE but similar dimensions are found on VSD-E. IGES model available.

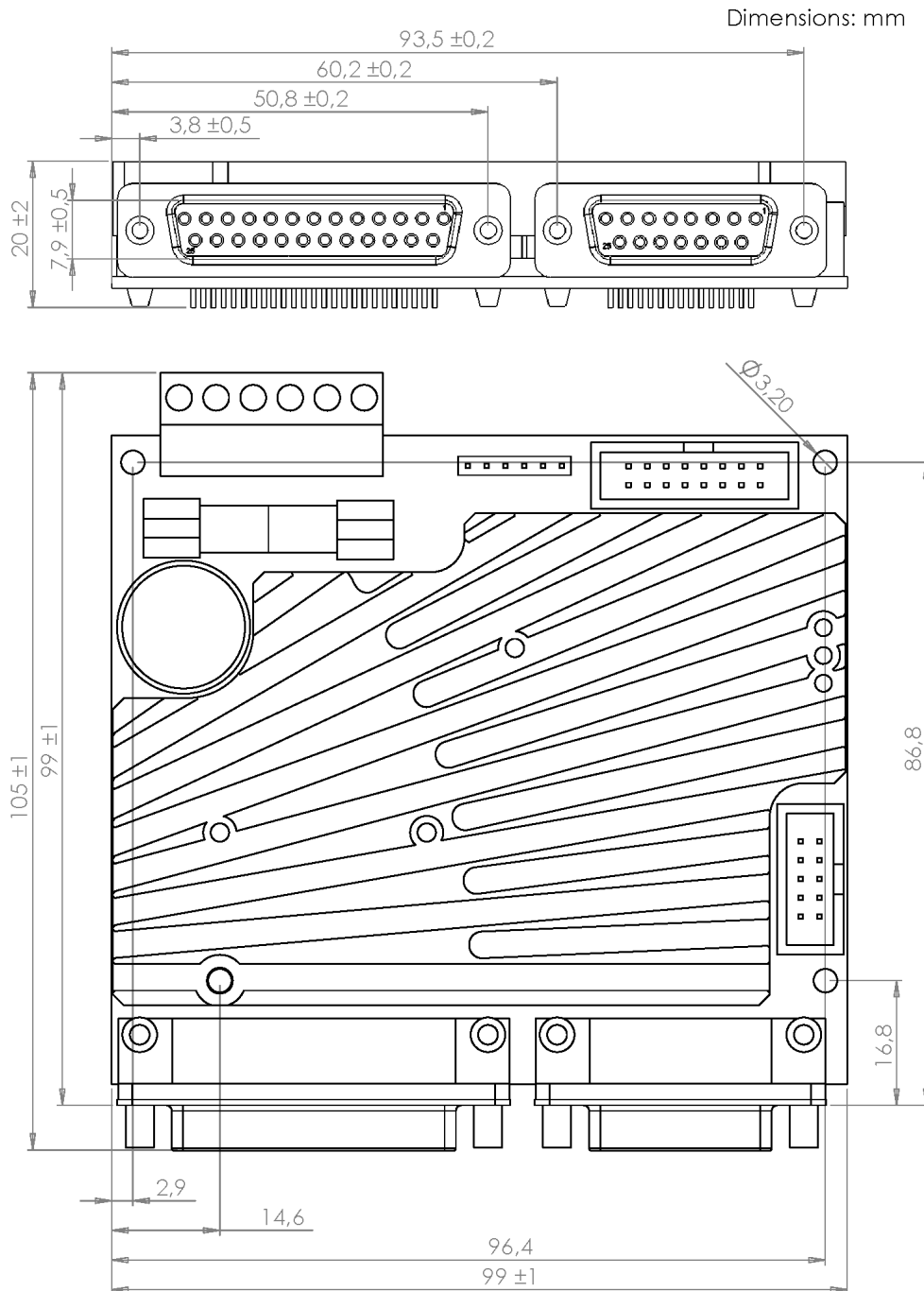

Granite Devices Oy
Opiskelijankatu 4 D 644
FI-33720 Tampere
Finland

+358 44 99 175 33
<http://www.granitedevices.fi>
VAT code FI20944279